

9-2015

Modeling Pitch Trajectories in Fastpitch Softball

Jean M. Clark

Meredith L. Greer

Bates College, mgreer@bates.edu

Mark D. Semon

Bates College, msemon@bates.edu

Follow this and additional works at: https://scarab.bates.edu/faculty_publications

Recommended Citation

Clark, J.M., Greer, M.L. & Semon, M.D., 2015, *Sports Engineering*, 18(3), 157-164. <https://doi.org/10.1007/s12283-015-0176-4>

This Article is brought to you for free and open access by the Departments and Programs at SCARAB. It has been accepted for inclusion in All Faculty Scholarship by an authorized administrator of SCARAB. For more information, please contact batesscarab@bates.edu.

Modeling Pitch Trajectories in Fastpitch Softball

Jean M. Clark · Meredith L. Greer ·
Mark D. Semon

Received: date / Accepted: date

Abstract The fourth-order Runge-Kutta method is used to numerically integrate the equations of motion for a fastpitch softball pitch and to create a model from which the trajectories of drop balls, rise balls and curve balls can be computed and displayed. By requiring these pitches to pass through the strike zone, and by assuming specific values for the initial speed, launch angle and height of each pitch, an upper limit on the lift coefficient can be predicted which agrees with experimental data. This approach also predicts the launch angles necessary to put rise balls, drop balls, and curve balls in the strike zone, as well as a value of the drag coefficient that agrees with experimental data. Finally, Adair's analysis of a batter's swing is used to compare pitches that look similar to a batter starting her swing, yet which diverge before reaching home plate, to predict when she is likely to miss or foul the ball.

Keywords Softball · pitching · differential equations · Runge-Kutta

1 Introduction

The game of fastpitch softball has been played since the late 1800's and is currently a popular women's sport in American high schools and colleges. Although the trajectories of many different spherical sports balls have been

J. M. Clark
Raytheon Corporation, 1001 Boston Post Road, Marlborough MA 01752

M. L. Greer
Department of Mathematics, Bates College, Lewiston ME 04240
Tel.: +207-786-6283
Fax: +207-753-6949
E-mail: mgreer@bates.edu

M. D. Semon
Department of Physics and Astronomy, Bates College, Lewiston ME 04240

investigated [1], those of a fastpitch softball have only recently begun to be studied [2, 3].

In this paper we study the dynamics of pitches in fastpitch softball. At first, one might not expect the properties and motion of a fastpitch softball to be much different from those of a major league baseball because both have the same Reynolds number for the speeds at which they are usually thrown. For example, experimental data confirm that the drag coefficient for a fastpitch softball is the same as that of a major league baseball. On the other hand, there are several significant differences between fastpitch softballs and major league baseballs. For example, the former has raised seams while the latter has flat seams. Since the seams of a spinning ball affect the flow of air around it, and since the spin speed that can be given to a fastpitch softball is different from that which can be given to a baseball, one might expect the degree to which each drops, rises, or curves to be different. Furthermore, there is some disagreement as to how the spin and linear speeds of a baseball affect the force that makes it curve. More specifically, the curve depends on the Magnus force, which itself depends on the lift coefficient of the ball. Several different functional dependencies of the lift coefficient have been proposed, and this is a topic that is still being investigated.

Thus, the lift coefficient of a fastpitch softball cannot be readily determined from the lift coefficient of a major league baseball, which means that the trajectories of major league baseballs and fastpitch softballs could have significant differences. This, in turn, could affect the strategies used in each game and the skills and perceptions a player needs to be successful.

In order to investigate these and other aspects of fastpitch softball pitches, a model based on Newton's equation is presented that simulates their motion. By assuming reasonable values for the angle, speed and height off the ground of a softball as it leaves the pitcher's hand, we compute and display the trajectories of rise balls, drop balls and curve balls. The model is then used to predict an upper bound on the lift coefficient of a fastpitch softball and show that this bound agrees with experimental data. The model also predicts the launch angles necessary for various pitches to pass through the strike zone, as well as a value of the drag coefficient which is consistent with experimental data. Using the time analysis of a batter's swing presented by Adair [4], we then discuss when a given pitch has a good chance of fooling a batter into starting her swing before she can accurately assess the trajectory of the ball and thus cause her to miss (or foul) it. Finally, we discuss how the agreement of our model with experimental data gives us confidence that it can be used to predict accurate trajectories of pitches thrown with different initial launch speeds, launch angles, or more general orientations of the axis of rotation.

2 Assumptions and initial conditions

The coordinate system used in our analysis has the x axis along a horizontal line from the pitcher to home plate, the y axis perpendicular to the ground,

and the z axis perpendicular to the x and y axes according to the right hand rule. The origin of the coordinate system is on the ground directly beneath the point where the ball leaves the pitcher's hand. The pitch is thrown from just above the origin at an initial height y_0 , so the coordinates of the launch point are $x_0 = 0, y_0, z_0 = 0$.

The angle φ is the angle the velocity vector makes with the z -axis, and θ is the angle made with the x -axis by the projection of the velocity vector in the $x - y$ (vertical) plane. Note that a pitch which remains in the vertical plane (and does not curve) has a constant angle of $\varphi = 90^\circ$. If the pitch is released perfectly horizontally (parallel to the ground) it has $\theta = 0^\circ$. A nice illustration of this coordinate system (shown with the y -axis in the horizontal rather than the vertical direction) is given by Arnold [5].

We model the motion of the fastpitch softball by assuming that once the ball leaves the pitcher's hand it is acted upon by three forces: gravity, air resistance and the Magnus force. The magnitude of the force of gravity is

$$F_g = mg, \quad (1)$$

where m is the mass of the softball and g is the gravitational acceleration, whose direction is along the negative y axis.

The magnitude of the force of air resistance is expressed in the standard form [6]

$$F_d = \frac{1}{2}C_D\rho Av^2, \quad (2)$$

where C_D is the drag coefficient, A is the cross-sectional area of the ball, v is the speed of the ball, and ρ is the density of air, which is 1.2 kg/m^3 for temperatures within the range of 16°C to 32°C (60°F to 90°F) [7]. The drag force acts in the direction opposite to that of the velocity.

The standard expression for the magnitude of the Magnus force is [6]

$$F_M = \frac{1}{2}C_L\rho Av^2, \quad (3)$$

where C_L is the lift coefficient. The Magnus force is created by the spin of the ball, and depending upon the direction of the spin axis, it leads to pitches that rise, curve or drop as they travel from the pitcher to home plate. The Magnus force acts in a direction perpendicular to both the angular and translational velocity of the ball. More precisely, if $\boldsymbol{\omega}$ is the angular velocity vector then the Magnus force is in the direction of $\boldsymbol{\omega} \times \mathbf{v}$.

Putting these forces into Newton's second law we find

$$m\dot{v}_x = -\frac{1}{2}C_D\rho A v_x \sqrt{v_x^2 + v_y^2 + v_z^2}, \quad (4)$$

$$m\dot{v}_y = -mg - \frac{1}{2}C_D\rho A v_y \sqrt{v_x^2 + v_y^2 + v_z^2} \quad (5)$$

$$+ \frac{1}{2}C_L\rho A (v_x^2 + v_y^2 + v_z^2) \sin \alpha, \quad (6)$$

$$m\dot{v}_z = -\frac{1}{2}C_D\rho A v_z\sqrt{v_x^2 + v_y^2 + v_z^2} \quad (7)$$

$$+\frac{1}{2}C_L\rho A (v_x^2 + v_y^2 + v_z^2)\cos\alpha. \quad (8)$$

In these equations the superscript dot signifies a time derivative. The x component of the velocity is denoted by v_x and similarly for the y and z components. The direction of the Magnus force vector is specified by the angle α , which lies in the y - z plane with $\alpha = 0$ when the Magnus force vector points along the positive z axis.

The initial speed of the pitch is v_i , and the initial values for v_x , v_y , and v_z are:

$$v_{x,i} = v_i \sin \varphi \cos \theta$$

$$v_{y,i} = v_i \sin \varphi \sin \theta$$

$$v_{z,i} = v_i \cos \varphi.$$

The fastpitch softball is an optic yellow sphere with at least 88 raised red thread stitches. Although the dimensions of softballs vary slightly, we assume that each softball has a circumference of 0.305 m (12 in), a radius of 0.0483 m (1.9 in) and a mass of 0.184 kg (which corresponds to a weight of 6.5 ounces) [8].

Some of the initial conditions will be the same for all of the pitches considered. The front of the softball pitching rubber (the side closest to the batter) is 13.1 m (43 ft) from the back of home plate [8] and, unlike in baseball, where there is a pitcher's mound, the rubber from which fastpitch softball pitchers throw is at the same level as the batter. A pitcher is permitted to take one stride towards the batter during her delivery. Since precise stride lengths vary by pitcher, and the depth of the strike zone is 0.43 m (17 in), our model assumes that every pitch travels 12.2 m (40 ft) in the direction of the x -axis during its flight from the pitcher to the strike zone.

The ball is released from a point just above the knee of the pitcher. As she steps forward to deliver a pitch her knee drops so we assume the release point is 0.46 m (1.5 ft) off the ground. This value of y_0 is close to those recorded by Nathan [3] (1.8 ft, $\sigma = 0.2$ ft) from four fastpitch softball pitchers. Finally, the initial speed of the softball is assumed to be 29 m/s (65 mph), which is consistent with values measured by Nathan [3] ($v_i = 65$ mph, $\sigma = 5$ mph) in over 3500 pitches, and with values reported by others.¹

The next step is to determine a numerical value for the drag coefficient C_D . If a fastpitch softball is assumed to be a scaled up major league baseball, then both the baseball and the softball will have the same drag coefficient when they have the same Reynolds number

¹ The Lisa Mize Fastpitch Academy reports the range of speeds for college fastpitch softball pitches as 59 to 70 mph [9].

$$R_e = \frac{\rho D v}{\mu}, \quad (9)$$

where D is the diameter of the ball and $\mu = 1.85 \cdot 10^{-5} \text{ N}\cdot\text{s}/\text{m}^2$ is the dynamic viscosity of air [6]. The diameter of a major league baseball is 0.074 m (2.9 in), so a softball moving at 29 m/s (65 mph) should have the same drag coefficient as a baseball moving at 38 m/s (85 mph).

Since the drag coefficient for a baseball moving with a speed of 38 m/s (85 mph) is about 0.33,² this value of C_D can be used in our equations. This number falls within the range of drag coefficients for fastpitch softballs found experimentally by Nathan ($C_D = 0.31, \sigma = 0.04$, private communication), which supports the assumption that in some ways a fastpitch softball behaves like a scaled up baseball (even though the softball has raised seams and the baseball has flat seams).

Continuing with the assumption that a fastpitch softball can be treated as a scaled up baseball, baseball pitches lose approximately 8–10% of their speed during their flight [4]. Using Figure 2.1 in [4], this corresponds to a change in drag coefficient of approximately 0.02, which does not significantly alter the value of C_D in equation (2). Thus, the drag coefficient can be assumed to be constant.

The dimensions of the strike zone vary from batter to batter. In this paper the strike zone is assumed to start 0.46 m (1.5 ft) above the ground (at the height of the top of the batter’s knees) and end 1.1 m (3.75 ft) above the ground (at the height of the batter’s forward armpit). The width of the strike zone is taken as the width of home plate (0.43 m, or 17 in) plus the diameter of a softball (0.10 m, or 3.8 in) since the rules specify that a pitch is a strike if any part of the ball crosses over the width of home plate. Thus, the width of the strike zone is taken to be 0.53 m (20.8 in). The strike zone provides the boundary for pitches in this analysis; that is, all pitches are required to pass through the strike zone.

The last parameter to discuss is the lift coefficient C_L . For baseballs, the degree to which C_L is affected by the orientation of the stitches with respect to the spin axis of the ball is not completely understood. Some analyses ignore the effect of seam orientation on the lift coefficient [10,11,12] while others indicate that there are at least a few cases in which the orientation of the seams can have a substantial effect on C_L [13].

In this paper, the model determines the range of allowed values for C_L for fastpitch softballs. A C++ program implementing the fourth-order Runge-Kutta method is used to numerically integrate the equations of motion (4) - (8), thereby obtaining the position of the softball as a function of time. Given that many of the input parameters are accurate to only two significant digits, a step size of 0.02 s is appropriate because smaller step sizes produce identical values (to two significant digits) for the calculated quantities of interest.

² See page 8 of Reference [4].

Table 1 Conditions for drop ball pitches

θ (degrees)	Range of C_L
5.0	0.00 – 0.05
5.5	0.00 – 0.11
6.0	0.00 – 0.16
6.5	0.00 – 0.22
7.0	0.00 – 0.27
7.5	0.00 – 0.33
8.0	0.04 – 0.38
8.5	0.10 – 0.44
9.0	0.16 – 0.50
9.5	0.21 – 0.56
10.0	0.27 – 0.62

In the program, the fixed parameters discussed above are entered first. Then θ and φ are chosen for the pitch of interest, and the program varies C_L from a minimum of 0.00 to a maximum of 1.00 in order to find the values of C_L which put the ball in the strike zone for those particular values of θ and φ .

3 Results

3.1 The drop ball

In the case of a drop ball, the Magnus force points in the negative y direction ($\alpha = -90^\circ$). Since the only other force acting in the y direction is gravity, the softball will only pass through the strike zone if there is a positive launch angle θ .

Table 1 shows the conditions necessary for a drop ball to pass through the strike zone for a range of launch angles. For example, if the drop ball leaves the pitcher's hand at an angle of $\theta = 6.0^\circ$ then the lift coefficient must be between 0.00 and 0.16 in order for the ball to cross home plate in the strike zone. The reason there is a range of acceptable values for the lift coefficient is because the ball will be a strike if it passes anywhere between the top and bottom of the strike zone.

Figure 1 shows the trajectory of a drop ball with a launch angle of $\theta = 6.0^\circ$ and a lift coefficient $C_L = 0.15$. Note that the scale on the y axis is smaller than the scale on the x -axis, so the vertical part of the trajectory displayed in the figure is somewhat exaggerated. In Figure 1, and in all subsequent figures, $x = 0$ m is the x -coordinate of the point at which the pitch is released from the pitcher's hand and $x = 12$ m (40 ft) is the x -coordinate of the end of the pitch.

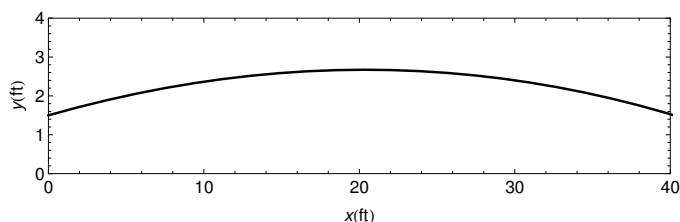

Fig. 1 The trajectory of a 29 m/s (65 mph) drop ball with an initial angle $\theta = 6.0^\circ$ and a lift coefficient $C_L = 0.15$.

Table 2 Conditions for rise ball pitches

θ (degrees)	Range of C_L
0.0	0.51 – 0.85
1.0	0.40 – 0.73
2.0	0.29 – 0.62
3.0	0.18 – 0.51
4.0	0.06 – 0.40
5.0	0.00 – 0.29
6.0	0.00 – 0.18
7.0	0.00 – 0.07

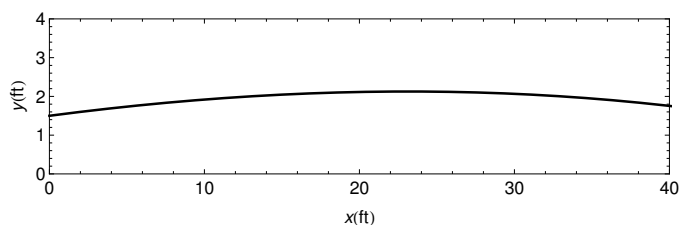

Fig. 2 The trajectory of a 29 m/s (65 mph) “rise ball” with an initial angle $\theta = 3.0^\circ$ and a lift coefficient $C_L = 0.20$. Note, however, that this pitch does not rise throughout its complete trajectory.

3.2 The rise ball

In the case of a pure rise ball, the Magnus force points in the positive y direction ($\alpha = 90^\circ$). Table 2 shows the range of values of C_L for which the ball will pass through the strike zone for various values of the launch angle θ . When $\theta \geq 8^\circ$ there is no (positive) value of C_L for which the pitch will be a strike.

For $\theta = 3.0^\circ$ and $C_L = 0.20$, the pitch stays in the strike zone but, as Figure 2 shows, the ball does not continue to rise throughout its complete trajectory. Figure 3 shows a rise ball pitch with $\theta = 6.0^\circ$ and $C_L = 0.18$ that does rise during its whole trip to home plate.

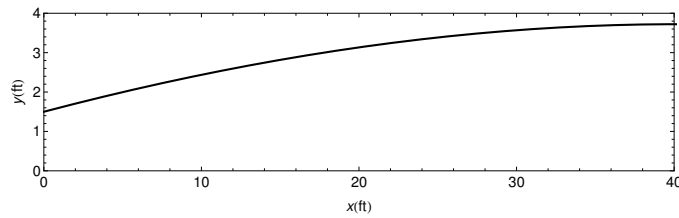

Fig. 3 The trajectory of a 29 m/s (65 mph) rise ball with an initial angle $\theta = 6.0^\circ$ and a lift coefficient $C_L = 0.18$. For these values of θ and C_L the ball rises throughout the whole trajectory.

Table 3 Conditions for curve ball pitches

φ (degrees)	Range of C_L
90.5	0.00 – 0.21
90.0	0.00 – 0.27
89.5	0.06 – 0.32
89.0	0.12 – 0.38
88.5	0.17 – 0.44
88.0	0.23 – 0.49
87.5	0.29 – 0.55

3.3 The curve ball

In the case of a pure curve ball, the Magnus force points in the negative z direction ($\alpha = 180^\circ$) and the softball curves to the pitcher’s left. (By calling this pitch a “curve ball” we are implicitly assuming the pitcher is right-handed. If the pitcher were left-handed this same pitch would be called a “screw ball.”)

Table 3 shows the conditions necessary for a curve ball to pass through the strike zone. In each case we have assumed a value of θ which keeps the ball within the strike zone’s vertical dimensions.

Pitches with values of φ less than 90° begin with a component of velocity in the positive z direction, opposite to the direction in which the ball will curve, which means they first travel slightly to the pitcher’s right before they curve to the left. The trajectory of a curve ball with launch angles $\theta = 4.5^\circ$ and $\varphi = 90^\circ$, and a lift coefficient $C_L = 0.15$, is shown in Figure 4. We stopped calculating trajectories when $\varphi = 87.5^\circ$ because fastpitch softball pitchers rarely produce a pitch with a value of C_L higher than about 0.30.

3.4 Other pitches

We can also compute and graph trajectories of pitches with the Magnus force vector pointing in any direction α in the y - z plane and any valid launch angles θ and φ , which we can think of as “rising screw balls,” “falling curve balls,” etc. Indeed, one way our model can be used is to display the trajectories of

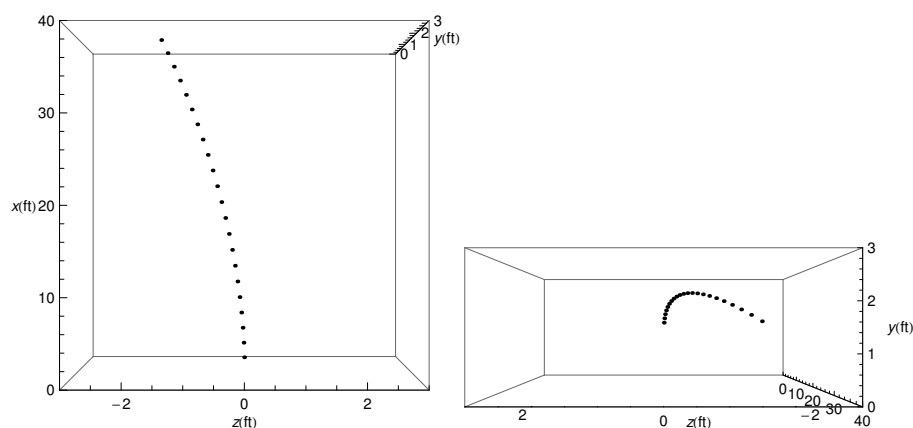

Fig. 4 The trajectory of a 29 m/s (65 mph) curve ball with $\theta = 4.5^\circ$, $\varphi = 90^\circ$ and a lift coefficient $C_L = 0.15$. (a) A view of the trajectory from above. (b) The batter's view of the trajectory. Note that in both cases the scale on the x axis is larger than the scales on the y and z axes.

these pitches for various values of C_L to estimate how much spin would be necessary to keep them in the strike zone.

4 Striking out the batter

We can use our results in conjunction with the time analysis of a typical batter's swing given by Adair [4] to get a better understanding of when a batter is most likely to miss or foul a pitch that passes through the strike zone. Our approach is to find out where the ball is when the batter must initiate her swing. If one type of pitch (say a rise ball) cannot be distinguished from another type of pitch (say a drop ball) before this time then the batter is likely to miss or foul the ball as it passes over home plate. Similarly, if a curve ball hasn't begun to curve when the batter must begin her swing then she is also likely to miss or foul it.

The first step in our approach is to determine the total time the ball is in the air as it travels from the pitcher to home plate. Numerical integration of Newton's equations shows that, for a softball whose initial speed is 29 m/s (65 mph) and whose drag coefficient is 0.33, this time is 0.45 s. Assuming no drag force, so the softball is traveling at a constant speed of 29 m/s (65 mph) from its release point to home plate, the time of flight is 0.42 s.

Note that the time for a baseball traveling at a constant speed of 38 m/s (85 mph) to reach home plate, which is 17 m (56 ft) away from the point where the pitch is released, is also 0.45 s. Similarly, if the baseball is traveling at 40 m/s (90 mph), it takes 0.42 seconds to reach home plate.³ Thus, a softball player must judge and react to a pitch in essentially the same short time interval as a

³ See page 60 of Reference [4] for more details.

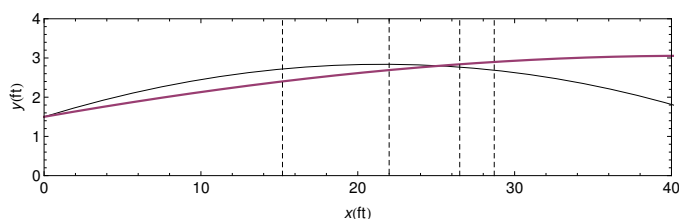

Fig. 5 The trajectory of a 29 m/s (65 mph) rise ball with an launch angle $\theta = 4.0^\circ$ and a lift coefficient $C_L = 0.30$ together with the trajectory of a drop ball with an launch angle of $\theta = 7.0^\circ$ and a lift coefficient $C_L = 0.25$. The first dashed line, at 4.6 m ($x = 15.2$ ft), shows the location of the ball at the last possible time by which the batter can start the Looking phase. The dashed lines at 6.7 m ($x = 22.0$ ft), 8.1 m ($x = 26.5$ ft) and 8.7 m ($x = 28.7$ ft) show the respective last locations of the ball at which the batter can start the Thinking, Action and Batting phases. Given the scale on the y -axis, the locations of the two pitches are just inches apart, almost indistinguishable to the batter, from the time the pitcher releases the softball until the time just before the batter initiates her swing. However, when the pitches cross home plate, they are over a foot apart.

baseball player, and Adair's analysis of a baseball batter's swing is also valid for the swing of a fastpitch softball player.

Adair's analysis of what happens during the batter's swing separates the batter's complete response into four parts: Looking, Thinking, Action, and Batting. The Looking portion of the swing takes about 75 milliseconds and is the time it takes the batter to cognize that the ball has left the pitcher's hand. The next part of the batter's process is the Thinking portion. During this part of the swing, which takes about 50 milliseconds, the brain estimates the ball's trajectory. The next part of the batter's process is the Action portion, which takes about 25 milliseconds. This is the time period during which the brain sends a message to the muscles to begin the swing. Finally, there is the Batting portion of the process, which takes approximately 150 milliseconds, during which the batter sets the bat in motion. Adair says an experienced player can make minor adjustments in the motion of the bat for about the first 50 – 100 milliseconds of the Batting portion of the swing, but these adjustments most likely won't result in a solid hit if the trajectory is not what the batter expected at the end of the Action portion of the swing.

Figure 5 shows the locations of a rise ball and a drop ball during each of the four parts of the batter's process. To compute this, we first determined the time at which the ball would be over home plate and called this the end of the Batting portion of the swing. Working backwards from this time determines where the ball is 150 milliseconds earlier, at the beginning of the Batting portion, and continues in this way to determine where the ball is at the beginning of the Action, Thinking and Looking phases. Comparing several pairs of rise ball and drop ball pitches yielded a pair in which both pitches ended in the strike zone at very different heights, yet throughout the batter's decision process described by Adair, the pitches differ by less than 0.10 m (4 in).

Figure 5 shows how hard it is for a batter to assess the trajectory of a pitch in time to get a solid hit. As the figure shows, the batter must commit to her swing at the end of the Action portion of her process, when the drop and rise ball trajectories are almost indistinguishable. When the balls cross home plate, however, the two trajectories are over 0.30 m (1 ft) apart, so if the batter has made the wrong choice at the beginning of her swing she most likely will miss or foul the ball.

Trajectories such as those shown in Figure 5 can be created and compared to see how likely it is that a batter will have difficulty distinguishing one pitch from another by the time she has to commit to a specific swing. They also can be used to show the trajectory of a single pitch, such as a curve ball, to see where the ball is when a batter must initiate her swing. As such, if the initial conditions for a specific pitcher (her launch speed, launch height, etc.) are used in the program, figures like Figure 5 could be useful in predicting whether her pitching will be effective against an opposing team.

5 Lift coefficients for a fastpitch softball

Although equations (2) and (3), in which the drag and lift coefficients are defined, have the same form, the coefficients themselves have different functional dependencies. For example, whereas the drag coefficient depends upon properties intrinsic to the ball and the air through which it travels, heuristic arguments [4,6] suggest that the lift coefficient should depend upon the spin ω of the ball and its linear speed v through the air, both of which can vary from pitch to pitch. Consequently, although the drag coefficient should be essentially the same for all pitches thrown at roughly the same speeds, we expect the lift coefficient to vary, and more generally, to lie within a bounded range determined by the maximum and minimum values of the spin and initial speed given to the ball.

Nathan [6] investigated lift coefficients for baseballs, first extracting values of C_L from data and then examining their functional dependence on the Reynolds number and a quantity called the “spin factor,” which is defined as $S = \omega R/v$. He found that for $75 \text{ mph} < v < 100 \text{ mph}$ and $0.15 < S < 0.25$, which are the ranges most relevant to baseball, C_L is independent of Reynolds number but does depend upon S . Nathan says his data are in “excellent agreement” with the parameterization of Sawicki *et.al.* [10]

$$C_L = 0.09 + 0.6S \quad (10)$$

when $S > 0.1$, and

$$C_L = 1.5S \quad (11)$$

when $S \leq 0.1$.

In order to investigate how C_L and S are related for fastpitch softballs, typical values for a softball’s angular speed ω are needed. RevFire[©] makes equipment which they claim measures ω for fastpitch softballs to within ± 0.25

revolutions per second [14, 15, 16]. Their measurements show that the average value of ω for drop balls is 20 revolutions per second (rps), for curve balls and screw balls is 21 rps, and for rise balls is 22 rps. More generally, they found that for most pitches $17 \text{ rps} < \omega < 32 \text{ rps}$. Using these values of ω it can be shown that the average value of S is about 0.22 for all four types of softball pitches when they are moving with a speed of 65 mph, and that S is within the range $0.18 < S < 0.34$. Note that this range of values has significant overlap with the corresponding range (mentioned above equation (10)) for baseballs.

Because the range in which the spin factor S falls for a fastpitch softball has significant overlap with the range of S for a baseball, we will assume the allowed values of C_L for a fastpitch softball can also be computed from Eqs. (10) and (11). Making this assumption, the average value of C_L for drop balls, rise balls, screw balls and curve balls moving at 29 m/s (65 mph) is found to be approximately 0.22, and C_L falls within the range $0.20 < C_L < 0.29$. Nathan (private communication) reports that a preliminary analysis of data taken from over 3500 fastpitch softball pitches of *all kinds*, thrown by four pitchers, found a similar upper bound for C_L (about 0.30) although a somewhat lower mean ($0.13, \sigma = 0.06$). Of course the mean is determined by how many of each type of pitch was thrown, which was not recorded.

The fact that the model predicts C_L to be bounded above by 0.30, and that this expectation is in agreement with experimental data, allows us to use the results presented in Tables I, II and III to draw several conclusions about launch angles. First, according to Table I, drop balls which pass through the strike zone can't have launch angles greater than about ten degrees. This prediction is consistent with the data presented by Nathan [3], which showed that θ has an average value of 7.4° with a root mean square value of 2.3° . Note that Nathan's launch angle data were taken for all types of pitches, not just drop balls. Second, according to Table II, rise balls must have a nonzero launch angle in order to pass through the strike zone and this angle must be greater than two degrees. This prediction is consistent with the data presented by Nathan [3], which show that there were no launch angles θ less than two degrees. Third, according to Table III, a pitch curving to the pitcher's left must be launched with a horizontal angle less than 2.5° to the right of the line between the pitcher and home plate if it is to have a chance of passing through the strike zone. At present there are no data with which to compare this prediction.

6 Conclusion

This paper presents a model based on Newton's Laws from which the trajectories of various pitches in fastpitch softball can be calculated and displayed. This model is used to graph the paths followed by drop balls, rise balls and curve balls for different choices of launch angles and lift coefficients, and to determine which combinations of these parameters result in pitches that pass through the strike zone. The model is then used, along with an analysis pre-

sented by Adair, to predict when a pitch is likely to be missed or fouled by a batter. Finally, lift coefficients C_L are considered for fastpitch softballs. The model predicts that C_L should be bounded above by 0.30, a result confirmed by recent experimental data. This upper bound is then used to place limits on the launch angles for which various pitches will stay within the strike zone, and these limits agree with experimental data.

Acknowledgements We thank Professor Alan Nathan of the University of Illinois at Urbana-Champaign, who read an earlier version of this manuscript and made many helpful suggestions. We also thank Professor Gwen Lexow, former Head Softball Coach at Bates College, for her insights into pitching.

References

1. Frohlich C (2011) Resource Letter-PS2: The Physics of Sports. *Am. J. Phys.* 79:565-574
2. Cross R (2011) *The Physics of Baseball and Softball*. Springer, New York
3. Nathan AM. *The Physics of Baseball: Fastpitch Softball Research*. <http://baseball.physics.illinois.edu/softball.html>. Accessed 4 February 2015
4. Adair RK (2002) *The Physics of Baseball*, 3rd edition. IT Books/Harper-Collins, New York
5. Arnold D. Spherical Coordinates in Matlab. <http://msemac.redwoods.edu/~darnold/math50c/mathjax/spherical/index.xhtml>. Accessed 2 February 2015
6. Nathan AM (2008) The effect of spin on the flight of a baseball. *Am. J. Phys.* 76:119-124
7. Air density table. Wind Atlas Analysis and Application Program. <http://130.226.56.171/Support/FAQ/WebHelp/AirDensityTable.htm>. Accessed 2 February 2015
8. Abrahamson D (2013) NCAA Softball: 2014 and 2015 Rules and Interpretations <http://www.ncaapublications.com/p-4319-2014-and-2015-softball-rules.aspx>. Accessed 2 February 2015
9. What's the Average Pitch Speed. Mize Fastpitch Diamonds. http://www.mizefastpitchdiamonds.com/news_article/show/9307?referrer_id=30863-news. Accessed 2 February 2015
10. Sawicki GS, Hubbard M, Stronge WJ (2003) How to hit home runs: Optimum baseball bat swing parameters for maximum range trajectories. *Am J. Phys.* 71:1152-1162
11. Watts RG, Ferrer R (1987) The lateral force on a spinning sphere: Aerodynamics of a curveball. *Am. J. Phys.* 55:40-44
12. Alaways LW, Hubbard M (2001) Experimental determination of baseball spin and lift. *J Sport Sci* 19:349-358
13. Cross R (2012) Aerodynamics in the classroom and at the ball park. *Am. J. Phys.* 80:289-297
14. Spin Rate Data. RevFire. http://www.revfire.com/coaching_data.html. Accessed 2 February 2015
15. FAQ. RevFire. <http://www.revfire.com/faq.html>. Accessed 2 February 2015
16. Fastpitch Softball Spin Rate Guide. RevFire. http://www.revfire.com/files/SpinRate_Guide_-_SB0_v7.pdf. Accessed 2 February 2015